

Spare Parts Kits

Objectives and Benefits



Objectives of this presentation. Expand expertise.

1. [Objectives](#) | 2. [Introduction](#) | 3. [Spare Parts Kits](#) | 4. [Benefits](#)

The aim of this presentation is to provide an
Objectives
of the LESER Spare Parts Kits.



Introduction.

1. [Objectives](#) | 2. [Introduction](#) | 3. [Spare Parts Kits](#) | 4. [Benefits](#)

What is a LESER “Spare Parts Kits”?

- A complete kit with just one article number, as a practical arrangement of most important spare parts
- Contains all parts that should be changed when dismantling the valve for routine service
- Typical contents: e.g. seals, gaskets, securing rings, screws, lubricants
- Not included: Reworked parts (discs, nozzles), spare parts dependent on the configuration (e.g. API: bellows, seals for lifting device H4)

LESER

The-Safety-Valve.com

Spare Parts Kits. Kit design and availability.

1. Objectives | 2. Introduction | 3. Spare Parts Kits | 4. Benefits

Including instructions on the identification and allocation of the components

Sturdy packaging with hanging eyelets

Plastic bags seal out dust and moisture

Each part is identified

Spare parts can be removed individually thanks to the snap-fit fasteners.



Spare Parts Kits are available for the following safety valves:

| API | High Efficiency | High Performance | Compact Performance |
|------------|-----------------|--------------------------------|---------------------|
| Series 526 | Series 810 | Type 441, 442 DIN | Type 459 |
| | Series 820 | Type 441, 442 ANSI | Type 462 |
| | | Type 441, 442 DIN Full nozzle | |
| | | Type 441, 442 ANSI Full nozzle | |

LESER

The-Safety-Valve.com

Spare Parts Kits. Contents of the API kit.

1. Objectives | 2. Introduction | 3. Spare Parts Kits | 4. Benefits

The kits are organised by orifice letter

| Orifice | Flange Class |
|---------|----------------|
| D – G | CL150 – CL2500 |
| H – L | CL150 – CL1500 |
| M – P | CL150 – CL900 |
| Q – R | CL150 – CL600 |
| T | CL150 – CL300 |

Materials

| Pos. | Components | Material | Quantity |
|------|----------------------|----------------------------------|----------|
| 7.5 | Securing ring (Disc) | 1.4571 316Ti | 1 |
| 14 | Split ring | 1.4404 316L | 2 |
| 57 | Ball | 1.4401 316 | 15 |
| 59 | Securing ring | 1.4571 316Ti | 1 |
| 60 | Gasket | Graphite/ 1.4401 Graphite/ 316 | 3 |
| 61 | Ball | 1.4401 316 | 1 |
| 66 | Screw | 1.4401 316 | 1 |
| 73.2 | Gasket (Lock screw) | 1.4401 316 | 1 |

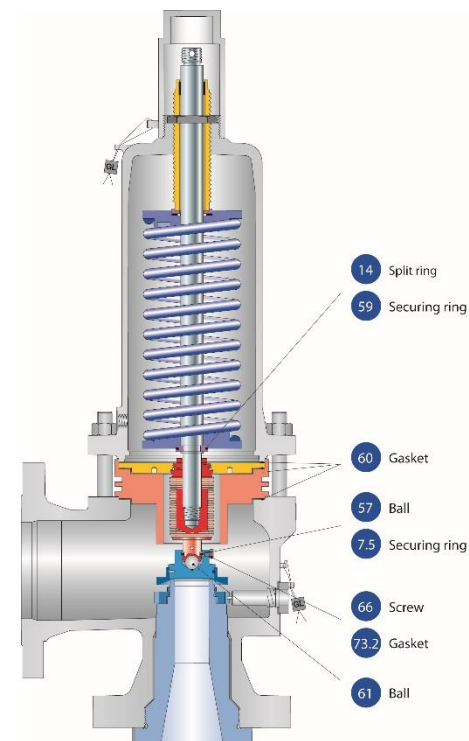

LESER

The-Safety-Valve.com

Spare Parts Kits. Contents of the POSV kits.

1. Objectives | 2. Introduction | 3. Spare Parts Kits | 4. Benefits

The POSV kits are separately available for the main valve and the pilot valve for all sizes.

| Valve size | 1 x 2 to 8 x 10 | | | | | | | | | | | | | |
|-----------------|-------------------|---|---|---|---|---|---|---|---|---|---|---|---|---|
| Orifice | D | E | F | G | H | J | K | L | M | N | P | Q | R | T |
| Flange class | CL150 – CL600 | | | | | | | | | | | | | |
| O-ring material | FKM EPDM FFKM | | | | | | | | | | | | | |

| Component for main valve | Component for pilot |
|--------------------------|-----------------------|
| All necessary gaskets | All necessary gaskets |
| All necessary O-rings | All necessary O-rings |
| Guide ring | All necessary O-rings |
| Back up ring | Lubricant oil |
| Parallel pin | |
| Screw | |
| Lubricant oil | |

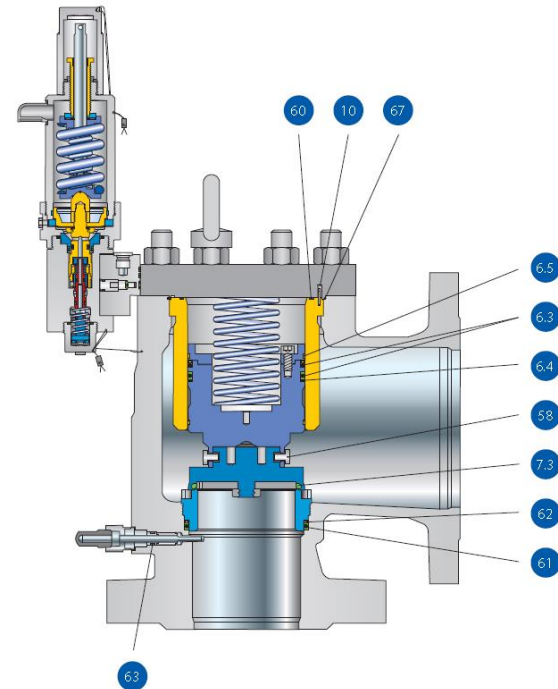

LESER

The-Safety-Valve.com

Spare Parts Kits. Contents of the high-performance kits.

1. Objectives | 2. Introduction | 3. Spare Parts Kits | 4. Benefits

Kits are available for nominal pressure levels from DN 20 to DN 200 of these types:

| Type |
|--------------------------------|
| Type 441, 442 DIN |
| Type 441, 442 ANSI |
| Type 441, 442 DIN Full nozzle |
| Type 441, 442 ANSI Full nozzle |

| Material | | | |
|----------|----------------------------|---------------------------------|------|
| Item | Component | Material | Qty. |
| 7.5 | Securing ring (disc) | 1.4571 316Ti | 1 |
| 14 | Split ring | 1.4404 316L | 2 |
| 57 | Pin | 1.4310 | 1 |
| 59 | Securing ring (split ring) | 1.4571 316Ti | 1 |
| 60 | Gasket | Graphite/ 1.4401 Graphite/ 316 | 3 |
| 61 | Ball | 1.4401 316 | 1 |
| 40.3 | Spacer | 1.4571 | 3 |

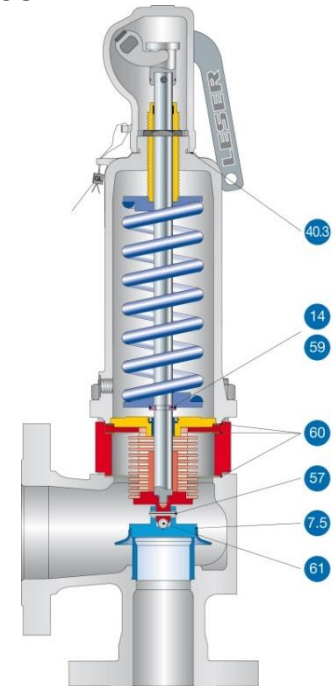

LESER

The-Safety-Valve.com

Spare Parts Kits. Contents of the compact-performance kits – Type 459.

1. Objectives | 2. Introduction | 3. Spare Parts Kits | 4. Benefits

Kits are available for sizes $d_0 = 9 \text{ mm}$ to 17.5 mm .

| Material Type 459 | | | |
|-------------------|----------------------------|-------------------------------------|------|
| Item | Component | Material | Qty. |
| 7 | Disc | 1.4404 316L | 1 |
| 14 | Split ring | 1.4404 316L | 2 |
| 57 | Pin | 1.4310 | 1 |
| 59 | Securing ring (split ring) | 1.4571 | 1 |
| 60 | Gasket | Graphite/ 1.4401 Graphite/ 316 | 2 |
| 63 | Gasket | Graphit/ 1.4401 Graphit/ 316 | 1 |
| 61 | Ball | 1.4401 316 | 1 |
| 40.3 | Spacer | 1.4571 | 3 |

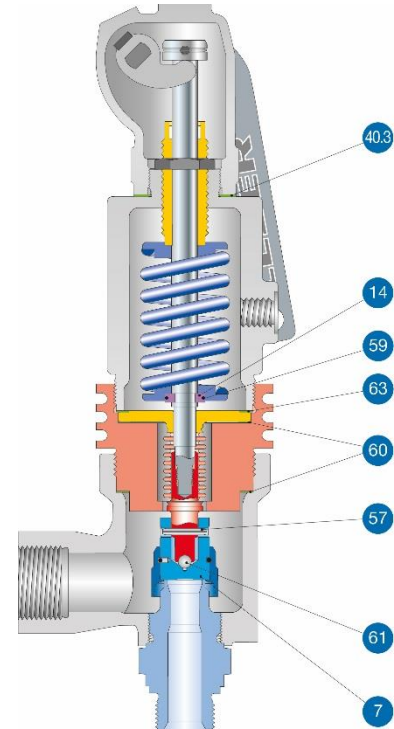

LESER

The-Safety-Valve.com

Spare Parts Kits. Contents of the compact-performance kits – Type 462.

1. Objectives | 2. Introduction | 3. Spare Parts Kits | 4. Benefits

Kits are available for sizes $d_0 = 9 \text{ mm}$ to 17.5 mm .

| Material Type 462 | | | |
|-------------------|----------------------------|-------------------------------------|------|
| Item | Component | Material | Qty. |
| 7.1 | O-ring disc body | 1.4571 316Ti | 1 |
| 7.2 | Lifting aid | 1.4404 316L | 1 |
| 7.4 | O-Ring (FKM/EPDM) | 1.4401 316 | 1 |
| 7.5 | Pin | 1.4404 316L | 2 |
| 14 | Split ring | 1.4401 316 | 2 |
| 59 | Securing ring (split ring) | 1.4404 316L | 1 |
| 57 | Pin | 1.4401 316 | 1 |
| 61 | Ball | 1.4571 316Ti | 1 |
| 60 | Gasket | Graphite/ 1.4401 Graphite/ 316 | 2 |
| 63 | Gasket | Graphite/ 1.4401 Graphite/ 316 | 1 |
| 40.3 | Spacer | 1.4401 316 | 3 |

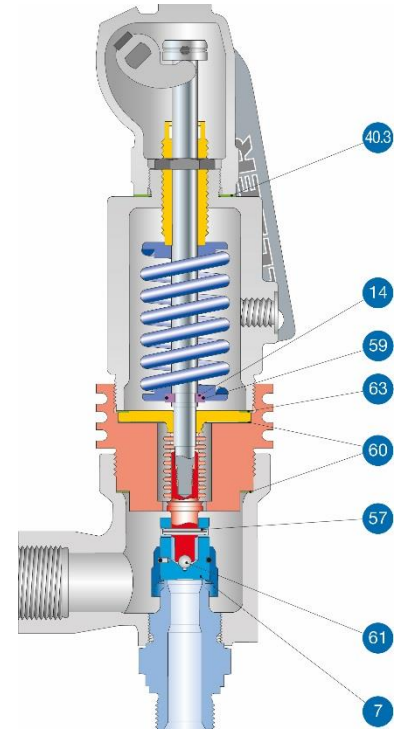

LESER

The-Safety-Valve.com

Benefits. Why use the LESER Spare Parts Kits?

1. [Objectives](#) | 2. [Introduction](#) | 3. [Spare Parts Kits](#) | 4. **Benefits**

- Availability
 - Rapid availability ex works or from many of our world-wide warehouses
- Easy handling of repair process
 - Easy and fast ordering
 - One article number reduces the effort and time for ordering
 - All necessary parts for disassembly and assembly
- Cost effective
 - Kits are less expensive than the sum of the individual parts

Spare Parts Kits

Thank you for your attention.

