

High Performance Series 441, XXL & 444 Product Profile, Features and Options



Objectives of this Presentation. Knowledge to learn.

1. [Objectives](#) | 2. [Remarks](#) | 3. [Applications](#) | 4. [Design](#) | 5. [Differentiation](#) | 6. [Features](#) | 7. [Benefits](#) | 8. [Materials](#) | 9. [Options](#) | 10. [Spare Parts Kit](#) | 11. [Approvals](#) | 12. [Differentiation](#)

The aim of this presentation is to provide an **overview** of the **LESER** product group **High Performance**.



LESER

The-Safety-Valve.com

General Remarks. High Performance Safety Valves.

1. [Objectives](#) | 2. [Remarks](#) | 3. [Applications](#) | 4. [Design](#) | 5. [Differentiation](#) | 6. [Features](#) | 7. [Benefits](#) | 8. [Materials](#) | 9. [Options](#) | 10. [Spare Parts Kit](#) | 11. [Approvals](#) | 12. [Differentiation](#)

LESER High Performance Safety Valves are the choice solution for all **industrial applications for steam, gas and liquid** with the following features:

- high capacity related to the valve size
- high adaptability
- excellent price/performance ratio



LESER

The-Safety-Valve.com

Application Area. Applications and References.

1. Objectives | 2. Remarks | 3. Applications | 4. Design | 5. Differentiation | 6. Features | 7. Benefits | 8. Materials | 9. Options | 10. Spare Parts Kit | 11. Approvals | 12. Differentiation

LESER High Performance safety valves are one of the best selling **spring loaded safety valves** worldwide and are used for, e.g.:

- Vessel protection (e.g. Heat Exchangers)
- Protection of equipment (e.g. Compressors and Pumps)
- Capacities beyond the limits of API
- Mainly used in PED influenced markets



LESER

The-Safety-Valve.com

Design

1. Objectives | 2. Remarks | 3. Applications | 4. Design | 5. Differentiation | 6. Features | 7. Benefits | 8. Materials | 9. Options | 10. Spare Parts Kit | 11. Approvals | 12. Differentiation

Series 441

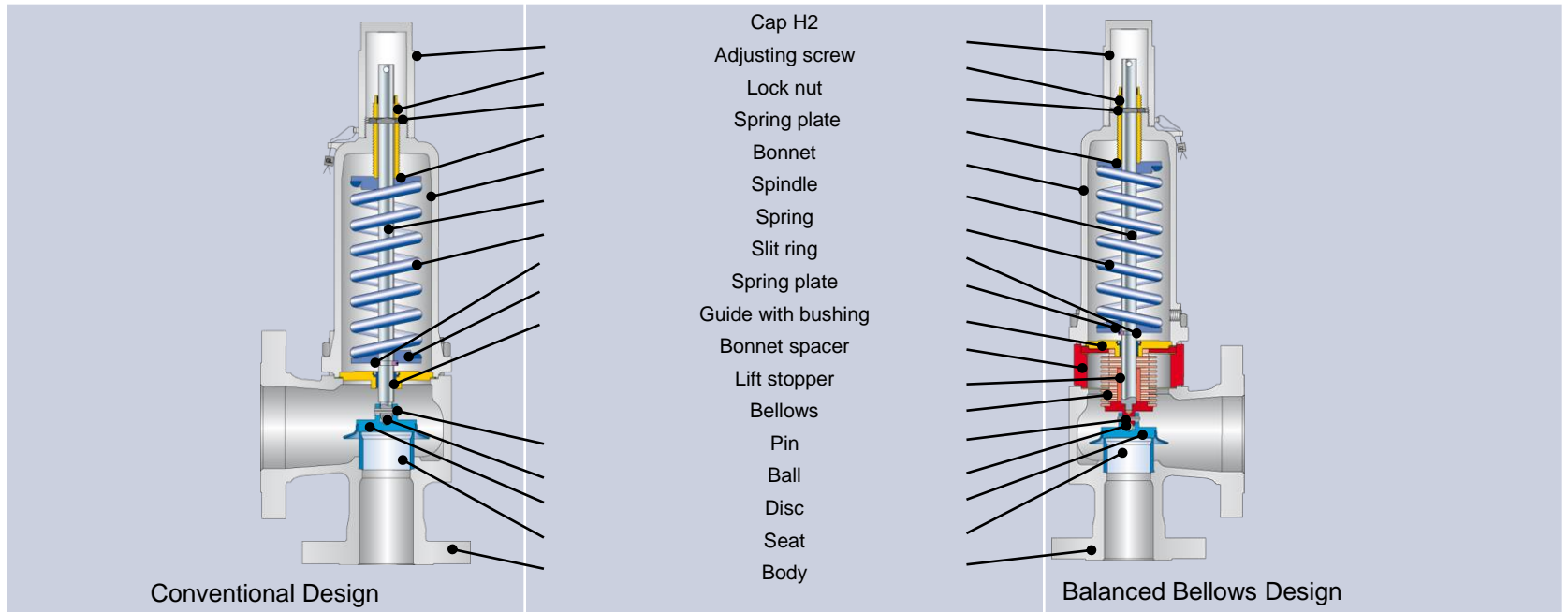

LESER

The-Safety-Valve.com

Differentiation. All High Performances types with ANSI and DIN flanges.

1. Objectives | 2. Remarks | 3. Applications | 4. Design | 5. Differentiation | 6. Features | 7. Benefits | 8. Materials | 9. Options | 10. Spare Parts Kit | 11. Approvals | 12. Differentiation

Orifice

3 x T

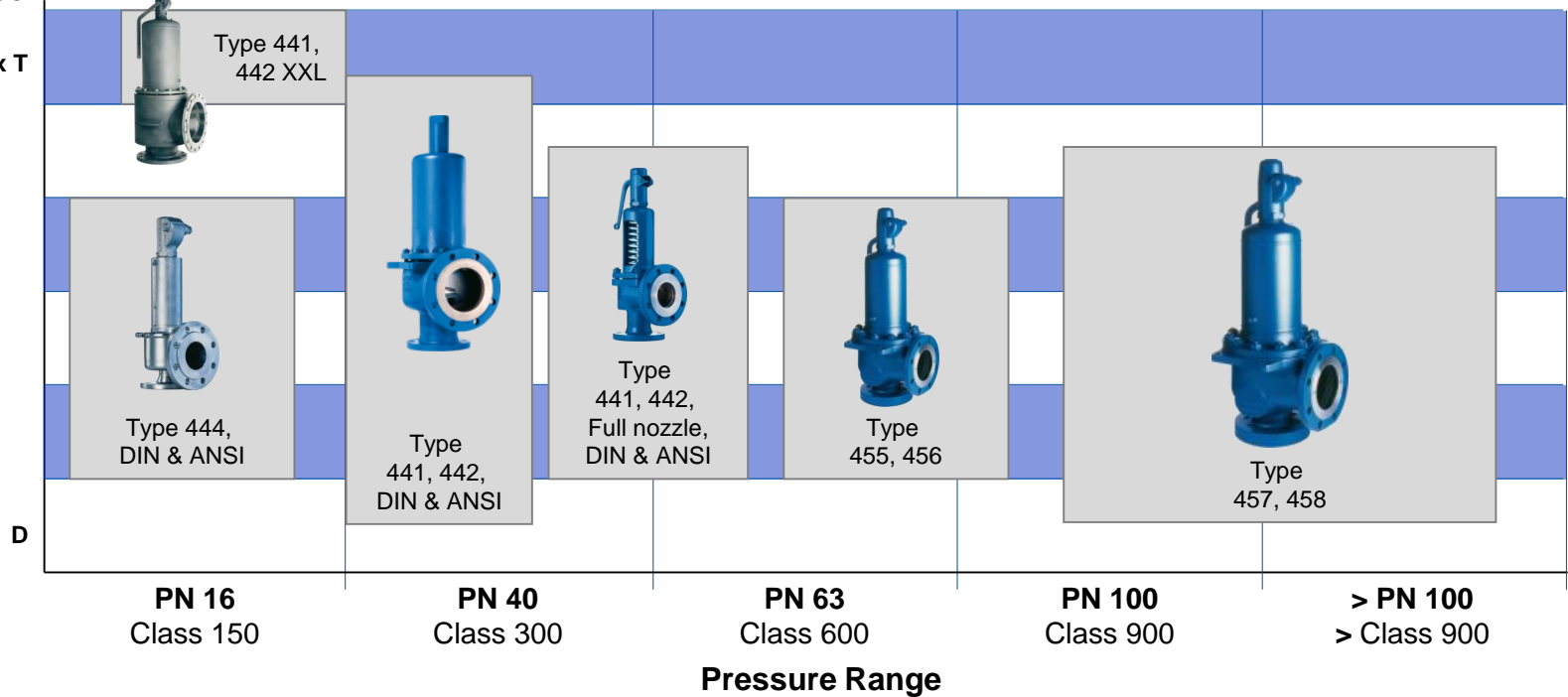

LESER

The-Safety-Valve.com

Main Features. Key figures in Metric Units

1. Objectives | 2. Remarks | 3. Applications | 4. Design | 5. Differentiation | 6. Features | 7. Benefits | 8. Materials | 9. Options | 10. Spare Parts Kit | 11. Approvals | 12. Differentiation

	Type 441, 442			Type 444	
	DIN	ANSI	XXL	DIN	ANSI
Size	DN 20 ... DN 200	1" x 2" ... 4" x 6"	DN 200 ... DN 400 8" x 10" ... 16" x 20"	DN 25 ... DN 80	1" x 2" ... 3" x 4"
Orifice	1,4 x E ... T	1,5 x F ... 1,3 x P	1,5 x R ... 3,3 x T	1,5 x F ... 1,2 x N	1,5 x F ... 1,2 x N
Set Pressure Range	0,1 bar ... 40 bar	0,1 bar ... 51 bar	0,2 bar ... 25 bar	0,1 bar ... 16 bar	0,1 bar ... 16 bar
Temperature	- 270° C ... + 450° C	- 270° C ... + 450° C	- 196° C ... + 550° C	- 45° C ... + 200° C	- 45° C ... + 200° C
Pressure Ratings	PN 16 ... PN 40	Class 150 x 150 ... Class 300 x 150	PN 16 ... PN 25	PN 16	Class 150 x 150

LESER

The-Safety-Valve.com

Main Features. Key figures in Metric Units.

1. Objectives | 2. Remarks | 3. Applications | 4. Design | 5. Differentiation | 6. Features | 7. Benefits | 8. Materials | 9. Options | 10. Spare Parts Kit | 11. Approvals | 12. Differentiation

	Type 441, 442 Full Nozzle		Type 455,456	Type 457, 458
	DIN	ANSI		
Size	DN 25 ... DN 50	1" x 2" ... 4" x 6"	DN 25 ... DN 100	DN 25 ... DN 150
Orifice	1,5 x F ... 1,1 x K	1,5 x F ... 1,3 x P	1,3 x F ... 1,4 x N	1,1 x E ... Q
Set Pressure Range	0,1 bar ... 40 bar	0,1 bar ... 51 bar	2,5 bar ... 100 bar	2,5 bar ... 300 bar
Temperature	- 270° C ... + 450° C	- 270° C ... + 450° C	- 85° C ... + 400° C	- 270° C ... + 550° C
Pressure Ratings	PN 16 ... PN 40	Class 150 x 150 ... Class 300 x 150	PN 63 ... PN 160	PN 63 ... PN 250

LESER

The-Safety-Valve.com

Main Features. Key figures in US Units.

1. Objectives | 2. Remarks | 3. Applications | 4. Design | 5. Differentiation | 6. Features | 7. Benefits | 8. Materials | 9. Options | 10. Spare Parts Kit | 11. Approvals | 12. Differentiation

	Type 441, 442			Type 444	
	DIN	ANSI	XXL	DIN	ANSI
Size	¾" x 1" ... 8" x 10"	1" x 2" ... 4" x 6"	8" x 10" ... 16" x 20"	DN 25 ... DN 80	1" x 2" ... 3" x 4"
Orifice	1,4 x E ... T	1,5 x F ... 1,3 x P	1,5 x R ... 3,3 x T	1,5 x F ... 1,2 x N	1,5 x F ... 1,2 x N
Set Pressure Range	1.5 psig ... 580 psig	3 psig ... 740 psig	3 psig ... 360 psig	1.5 psig ... 232 psig	1.5 psig ... 232 psig
Temperature	- 450° F ... + 800° F	- 450° F ... + 800° F	- 300° F ... + 800° F	- 49° F ... + 392° F	- 49° F ... + 392° F
Pressure Ratings	PN 16 ... PN 40	Class 150 x 150 ... Class 300 x 150	PN 16 ... PN 25	PN 16	Class 150 x 150



The-Safety-Valve.com

Main Features. Key figures in US Units.

1. Objectives | 2. Remarks | 3. Applications | 4. Design | 5. Differentiation | 6. Features | 7. Benefits | 8. Materials | 9. Options | 10. Spare Parts Kit | 11. Approvals | 12. Differentiation

	Type 441, 442 Full Nozzle		Type 455,456	Type 457, 458
	DIN	ANSI		
Size	1" x 2" ... 2" x 3"	1" x 2" ... 4" x 6"	1" x 2" ... 4" x 6"	1" x 2" ... 6" x 8"
Orifice	1,5 x F ... 1,1 x K	1,5 x F ... 1,3 x P	1,3 x F ... 1,4 x N	1,1 x E ... Q
Set Pressure Range	1.5 psig ... 580 psig	1.5 psig ... 740 psig	36 psig ... 1,450 psig	36 psig ... 4,350 psig
Temperature	- 450° F ... + 800° F	- 450° F ... + 800° F	- 300° F ... + 800° F	- 450° F ... + 1,000° F
Pressure Ratings	PN 16 ... PN 40	Class 150 x 150 ... Class 300 x 150	Class 300 x 150 ... Class 600 x 300	Class 300 x 150 ... Class 600 x 300

The-Safety-Valve.com

Benefits.

1. Objectives | 2. Remarks | 3. Applications | 4. Design | 5. Differentiation | 6. Features | 7. Benefits | 8. Materials | 9. Options | 10. Spare Parts Kit | 11. Approvals | 12. Differentiation

- **Rapid opening** with an overpressure of **5% to full lift**
- Maximum **blowdown** of **minus 10% for steam/gas** service (for ASME markets within 7%) and **20% for liquid service**
- **One design and spring** for steam, gas, liquid and multi-phase (single trim)
- One-piece spindle for **optimized setting accuracy and less friction**
- Few spare parts **minimized product life cycle costs**
- Self-draining body design **prevents from residues and reduces corrosion**
- **Integral cast support brackets** for easy handling and safe installation



LESER

The-Safety-Valve.com

Materials. According to DIN EN Standards.

1. Objectives | 2. Remarks | 3. Applications | 4. Design | 5. Differentiation | 6. Features | 7. Benefits | 8. Materials | 9. Options | 10. Spare Parts Kit | 11. Approvals | 12. Differentiation

Body Materials	0.6025	0.7043	1.0619	1.4404	1.4408	1.4060 / 1.0425	1.4571	1.4581	1.7357
Type 441, 442 DIN	X	X	X		X				
Type 441, 442 ANSI			X		X				
Type 441, 442 XXL						X	X		
Type 444 DIN				X					
Type 444 ANSI				X					
Type 441, 442 Full Nozzle DIN			X		X				
Type 441, 442 Full Nozzle ANSI			X		X				
Type 455, 456			X					X	
Type 457, 458			X					X	X

LESER

The-Safety-Valve.com

Materials. According to ASME Standards.

1. Objectives | 2. Remarks | 3. Applications | 4. Design | 5. Differentiation | 6. Features | 7. Benefits | 8. **Materials** | 9. Options | 10. Spare Parts Kit | 11. Approvals | 12. Differentiation











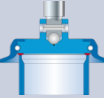
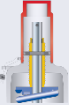

Body Materials	Cast iron	Ductile Gr. 60-40-18	WCB	316L	CF8M	Carbon steel	1316Ti	CF10M	WC6
Type 441, 442 DIN	X	X	X		X				
Type 441, 442 ANSI			X		X				
Type 441, 442 XXL						X	X		
Type 444 DIN				X					
Type 444 ANSI				X					
Type 441, 442 Full Nozzle DIN			X		X				
Type 441, 442 Full Nozzle ANSI			X		X				
Type 455, 456			X					X	
Type 457, 458			X					X	X

LESER

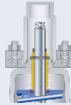
The-Safety-Valve.com

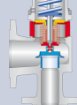
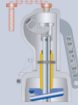
Options.

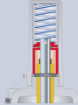
1. Objectives | 2. Remarks | 3. Applications | 4. Design | 5. Differentiation | 6. Features | 7. Benefits | 8. Materials | 9. Options | 10. Spare Parts Kit | 11. Approvals | 12. Differentiation

 Heating jacket	 Open bonnet	 O-ring disc	 Disc with sealing plate	 Disc stellited
 Screwed cap H2	 Plain lever H3	 Packed lever H4	 Bolted cap H1	 Bolted lifting device H6
 Drain hole	 Stainless steel bellows	 Test gag	 Lift indicator	 O-ring-damper H2
 Sour gas acc. to NACE MRO103 and MRO175				

LESER

The-Safety-Valve.com

Spare Part Kits. Contents of the high-performance kits.

1. Objectives | 2. Remarks | 3. Applications | 4. Design | 5. Differentiation | 6. Features | 7. Benefits | 8. Materials | 9. Options | 10. Spare Parts Kit | 11. Approvals | 12. Differentiation

Kits are available for nominal pressure levels from DN 20 to DN 200 of these types:

Type
Type 441, 442 DIN
Type 441, 442 ANSI
Type 441, 442 DIN Full nozzle
Type 441, 442 ANSI Full nozzle

Material			
Item	Component	Material	Qty.
7.5	Securing ring (disc)	1.4571 316Ti	1
14	Split ring	1.4404 316L	2
57	Pin	1.4310	1
59	Securing ring (split ring)	1.4571 316Ti	1
60	Gasket	Graphite/ 1.4401 Graphite/ 316	3
61	Ball	1.4401 316	1
40.3	Spacer	1.4571	3

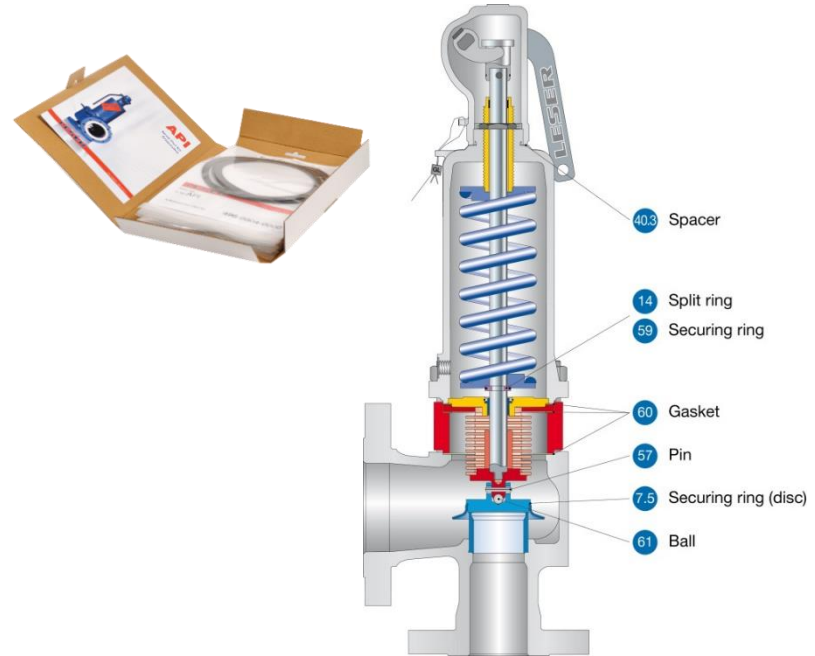

Approvals.

1. [Objectives](#) | 2. [Remarks](#) | 3. [Applications](#) | 4. [Design](#) | 5. [Differentiation](#) | 6. [Features](#) | 7. [Benefits](#) | 8. [Materials](#) | 9. [Options](#) | 10. [Spare Parts Kit](#) | 11. **Approvals** | 12. [Differentiation](#)

Worldwide approvals with one design.

Europe	DIN EN ISO 4126-1
Germany	AD 2000-Merkblatt A2
United States	ASME Sec. VIII Div. 1
Canada	CRN
China	AQSIQ
Eurasian Custom Union	EAC



LESER

The-Safety-Valve.com

Differentiation. API vs. High Performance

1. Objectives | 2. Remarks | 3. Applications | 4. Design | 5. Differentiation | 6. Features | 7. Benefits | 8. Materials | 9. Options | 10. Spare Parts Kit | 11. Approvals | 12. Differentiation

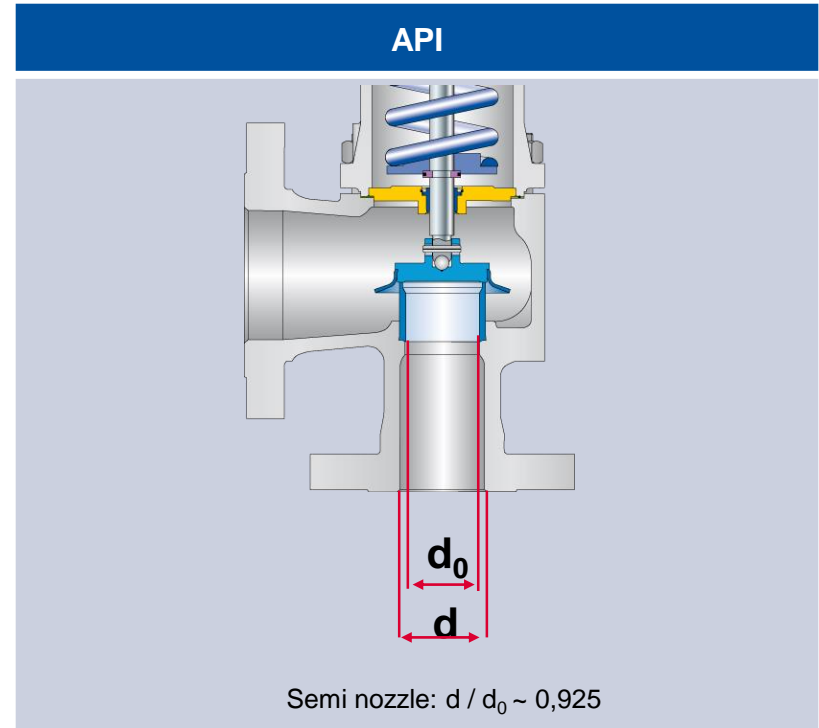
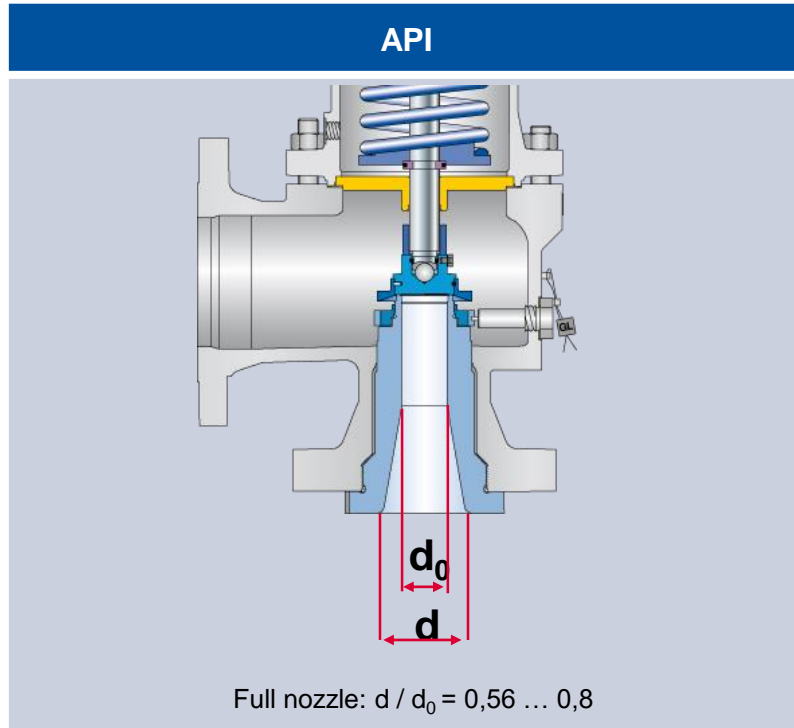

LESER

The-Safety-Valve.com

High Performance Series 441, XXL and 444
Thank you for your attention.



LESER

The-Safety-Valve.com